



Morse Micro
reaching farther™

PRODUCT BRIEF

MM6108 Overview

IEEE 802.11ah Sub-1 GHz 1/2/4/8 MHz BW MAC/PHY/Radio Wi-Fi HaLow SoC

Overview

The MM6108 System on Chip (SoC) is a single-chip solution providing complete Wi-Fi HaLow® connectivity through Radio, PHY, and MAC sections.

Designed in accordance with the IEEE 802.11ah standard, the SoC supports data rates up to 32.5 Mbps, and provides operation in the sub-1 GHz range (licence exempt from RF bands worldwide).

The RF interface for the MM6108 includes the option to use either the on-chip amplification for typical low-power, low-cost devices, or in conjunction with an external PCB-mount power

amplifier (PA) or Front-End Module (FEM) for ultra-long-reach applications.

The RF receiver features a high linearity LNA, making the use of external filters unnecessary in many applications.

Battery-operated applications are supported by a combination of features in the MM6108. The IEEE 802.11ah standard provides for extended sleep times of battery-operated STA client devices, with longer durations than other prior IEEE 802.11a/b/g/n/ac generations.

For Internet of Things (IoT) and Machine-to-Machine (M2M) applications:



- ✔ Surveillance cameras and sensors
- ✔ Cloud connectivity
- ✔ Building automation systems (BAS)
- ✔ Machine performance monitors and sensors
- ✔ Building access control & security
- ✔ Drone video and navigation communications
- ✔ Rural internet access
- ✔ Utility smart meter and intelligent grids
- ✔ Industrial automation controls
- ✔ Smart home automation
- ✔ Wi-Fi HaLow® access points and bridges
- ✔ Wi-Fi HaLow® client adapters/dongles
- ✔ Smart city networks

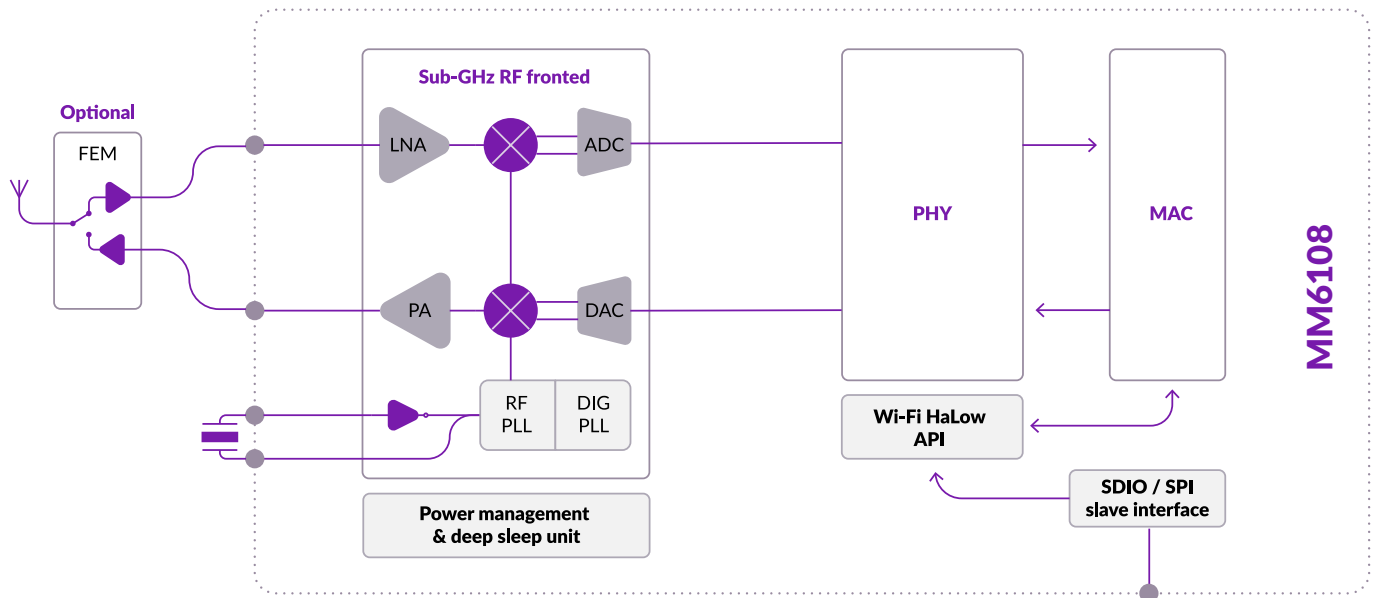

Single-chip IEEE802.11ah Wi-Fi HaLow® transceiver for low-power, long-reach IoT



Radio supporting worldwide sub 1GHz bands



Single-stream max data rate of 32.5 Mbps



On-chip power amplifier, external FEM option



6 x 6 x 0.85 mm QFN48 package



Power management unit (PMU) supporting ultra-low-power operation



SDIO 2.0 and SPI host interface options



GPIO/UART/I2C/PWM peripheral options



WPA3 security



1/2/4/8 MHz channel bandwidth

Wi-Fi HaLow Modulation and Coding Scheme

MCS index	Modulation scheme	Coding rate	PHY rate (kbps) per BW			
			1 MHz	2 MHz	4 MHz	8 MHz
10	BPSK	1/2 x 2	167		N/A	
0	BPSK	1/2	333	722	1500	3250
1	QPSK	1/2	667	1444	3000	6500
2	QPSK	3/4	1000	2167	4500	9750
3	16-QAM	1/2	1333	2889	6000	13000
4	16-QAM	3/4	2000	4333	9000	19500
5	64-QAM	2/3	2667	5778	12000	26000
6	64-QAM	3/4	3000	6500	13500	29250
7	64-QAM	5/6	3333	7222	15000	32500

For more product information: www.morsemicro.com

Copyright © 2024 Morse Micro. All Rights Reserved. Morse Micro® is the trademark of Morse Micro. Any other trademarks or trade names mentioned are the property of their respective owners. January 2024



Morse Micro
reaching farther™